

## GRIPPER for JERSEY, CONCRETE ROAD BARRIERS CLAMP



MODEL	CAPACITY	GRAB WIDTH	GRAB DEPTH	JAWS LENGTH	TARE
	[kg]	[mm]	[mm]	[mm]	[kg]
11130	5000	25 ÷ 425	200	500	220

### SUPPLY BASE MODEL 11130:

Semi-automatic locking pliers  
 Jaws of cut-resistant rubber grip  
 Galvanization

## AVAILABLE STANDS



### Jaws of black rubber grip

Reliable grip: Gripper for new jersey Barrier Lifts provide a safe, easy, and efficient solution for lifting and placing concrete barrier wall. Exclusive elastomer grips provide superior performance, even in inclement weather. These rugged barrier tongs provide full surface contact without damaging the concrete. The socket can leave a slight black mark. The rubberized surface is subject to wear and, if used on very rough surfaces, can be damaged due to the strong tension.



### Semi-automatic locking

Standard configuration of the clamp is necessary to act on the release lever. The hang-up which leads to the release of the raised piece is automatic.



### Special colors on request

The standard surface finish is galvanized. Color choice can be customized.



### Iron Clamps

Equipped with sharp projections that penetrate the surface, providing maximum hold. Very suitable for frequent and intense use and for the handling of motorway barriers, such as New Jersey. This accessory slightly damages the surface.



### Automatic lock of the clamp

The phases of attachment and release of the gripper are managed independently by a simple mechanical system. In doing so, the crane operator is able to manage the gripper without necessarily be close it.

## CLAMP FOR LIFTING OF CONCRETE BLOCKS

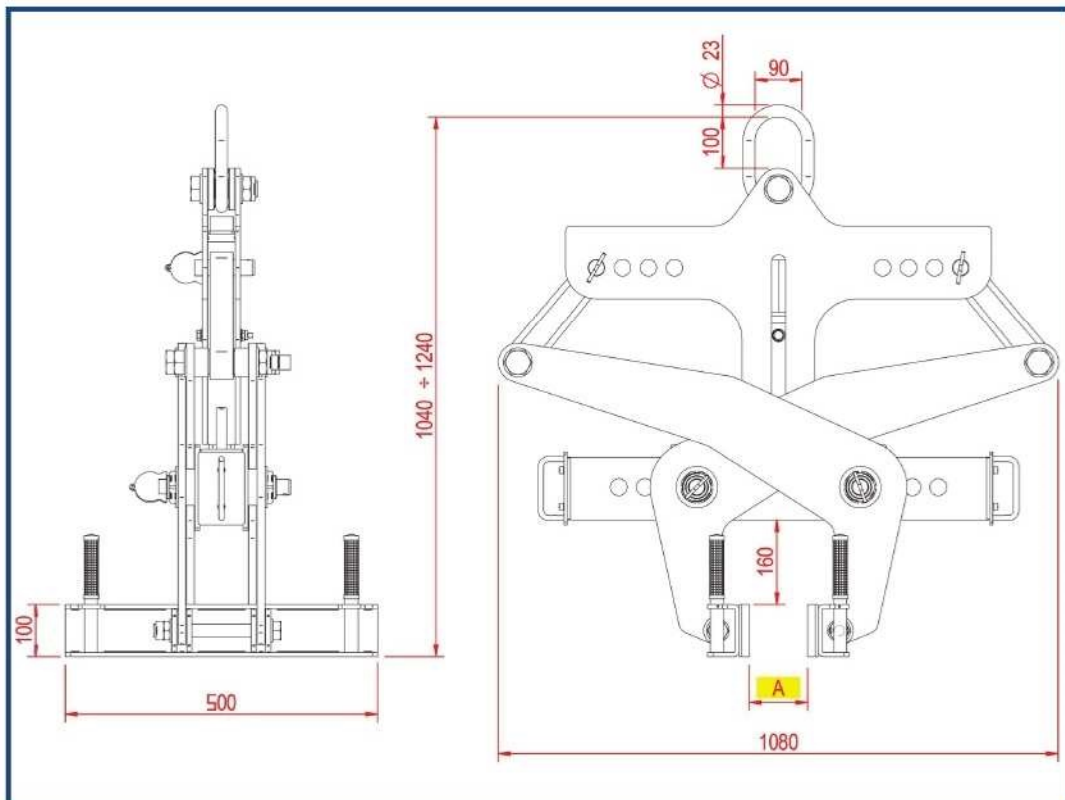

Maximum capacity: 5000 kg.

Opening range: O + 400 mm.

Surface finish: Zinc plated.

Tilting jaws with spring return to adapt the outlet inclined surfaces.

Supplied with ring for suspension.

Supplied with locking semi-manual - Optional: automatic locking.

Supplied with rubber sockets - Optional: made of hardened steel.

The product is CE certified and accompanied by instructions for use and maintenance.